

30T Series

30W TRIPLE OUTPUT

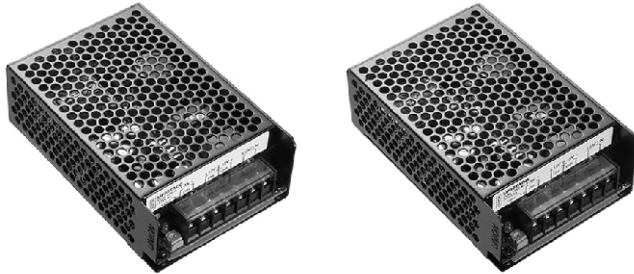

- ▶ Constant voltage design
- ▶ Wide input range
- ▶ Protection : Over load /Over voltage/Short circuit
- ▶ 100% full load burn-in test
- ▶ Suitable for industrial applications
- ▶ 3years warranty

SPECIFICATIONS

Item		UP30TACC			UP30TADD		
INPUT	VOLTAGE	AC85~264V			0.7A typ (ACIN 110V, Io=100%) 0.35A typ (ACIN 220V, Io=100%)		
	FREQUENCY	50/60Hz(47~63Hz)					
	EFFICIENCY	65% Typ			65% Typ		
	INRUSH CURRENT	20A Typ(ACIN 110V, Io=100%)/40A Typ(ACIN 220V, Io=100%) at cold start					
OUTPUT	VOLTAGE [V]	5	12	-12	5	15	-15
	CURRENT [A]	3.0	1.0	0.2	3.0	0.8	0.2
	LINE REGULATION [mV]	25 Max	60 Max	60 Max	25 Max	75 Max	75 Max
	LOAD REGULATION [mV]	50 Max	120 Max	120 Max	50 Max	150 Max	150 Max
	RIPPLE [mVp-p]	50 Max	120 Max	120 Max	50 Max	150 Max	150 Max
	RIPPLE NOISE [mVp-p]	100 Max	170 Max	170 Max	100 Max	200 Max	200 Max
	TEMPERATURE DRIFT,0-50℃ [mV]	50 Max	120 Max	120 Max	50 Max	150 Max	150 Max
	RISE TIME [msec]	100 Max (ACIN 85V, Io=100%)					
HOLDING TIME [msec]	10 Typ(ACIN 85V, Io=100%)						
PROTECTION	OVER CURRENT PROTECTION	Works at over 110% of rating and recovers automatically					
	OVER VOLTAGE PROTECTION	Works at 115~140% of rating					
ISOLATION	INPUT-OUTPUT	AC3,000V for 1 minute, DC500V 100Mohm (At room temp. & humid.)					
	INPUT-CASE, FG	AC1,500V for 1 minute, DC500V 100Mohm (At room temp. & humid.)					
	OUTPUT-CASE	AC500V for 1 minute, DC500V 100Mohm (At room temp. & humid.)					
ENVIRONMENT	OPERATING TEMP. & HUMID.	-10~+60℃(refer to "DERATING CURVE),20~90%RH					
	STORAGE TEMP. & HUMID.	-10~+75℃,20~90%RH					
	VIBRATION	10~55Hz at 1G 3 minutes period, 30 minutes along X, Y and Z axis					
	IMPACT	10G for 20 msec, Once on each X, Y and Z axis					

S.M.P.S

Enclosed Switching Power Supply

General Type

BLOCK DIAGRAM

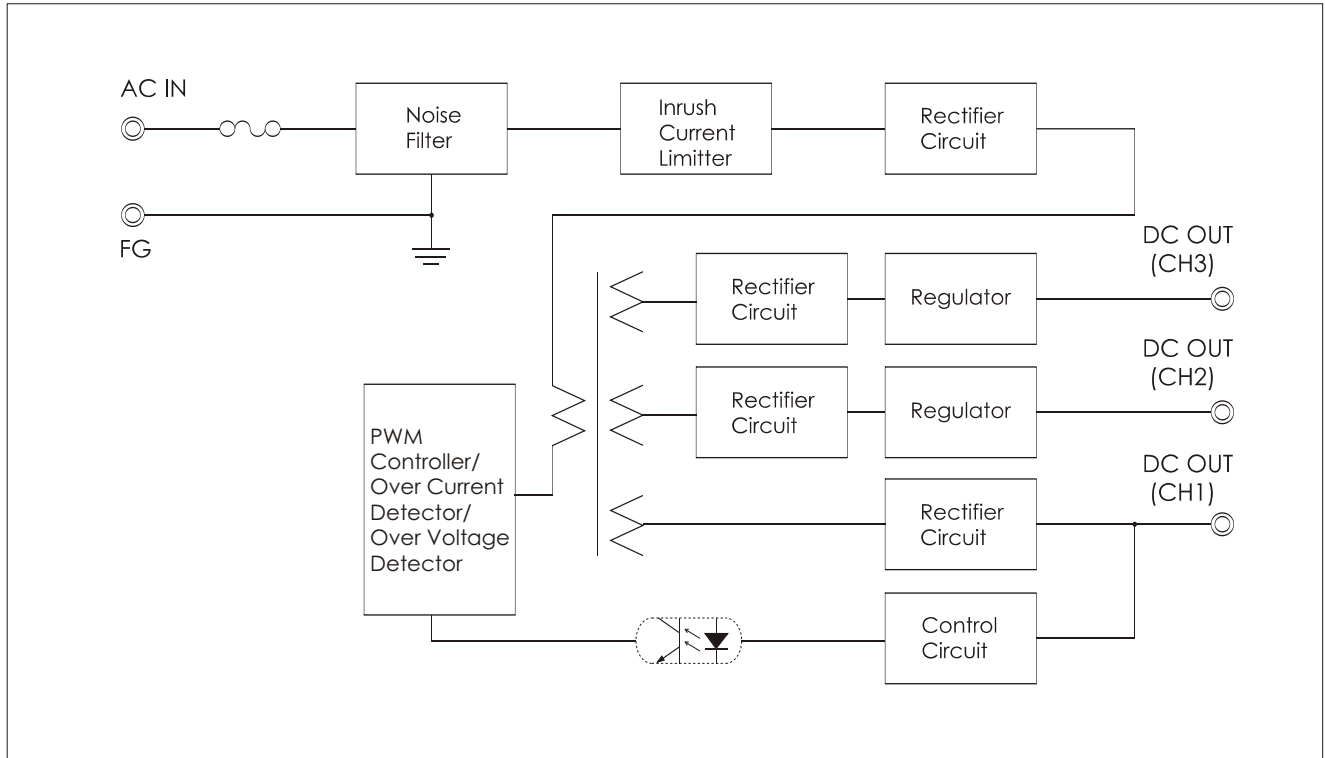

DIMENSIONS(UNITS : MM)

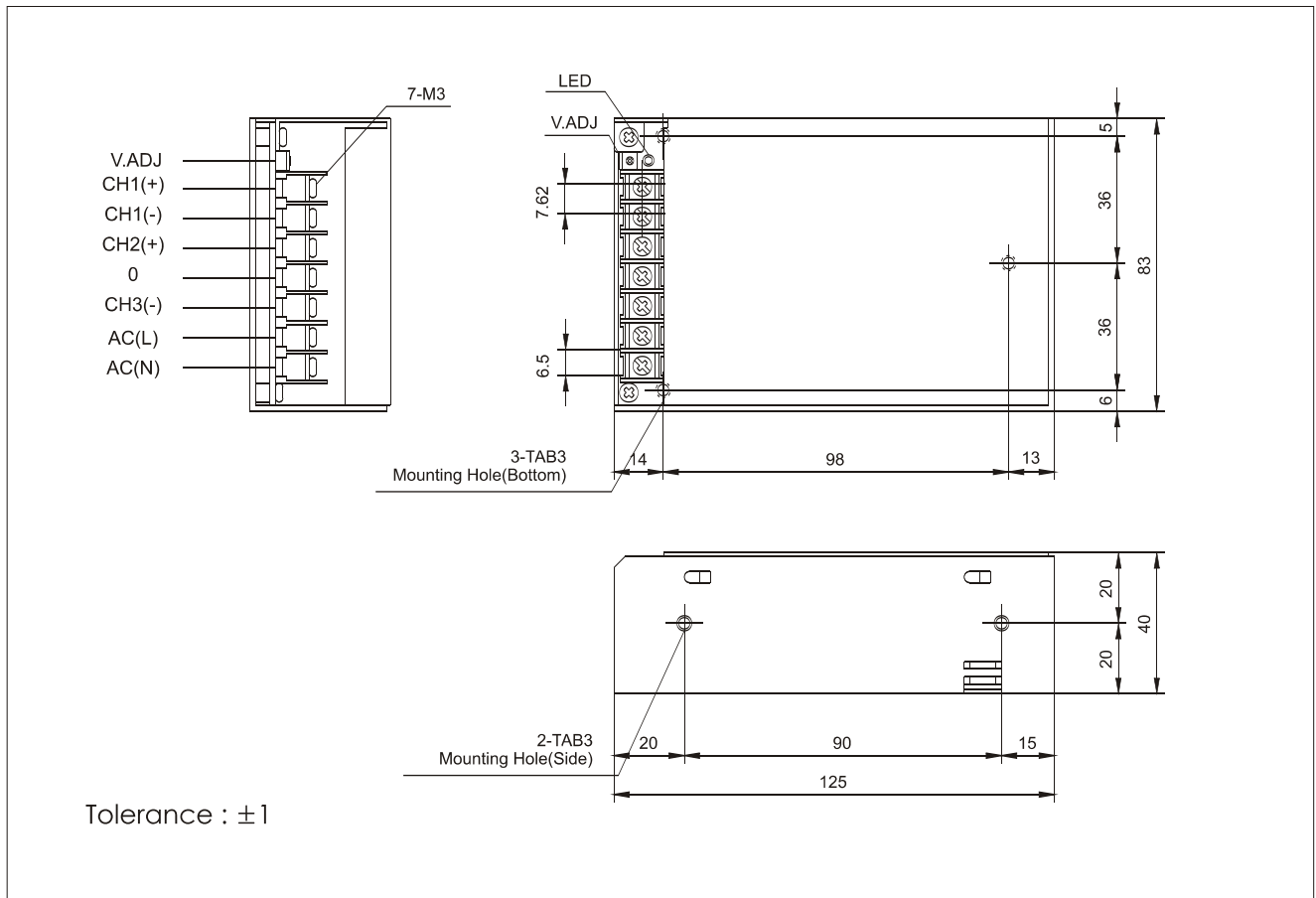

Characteristic curve

*(UP30TACC MODEL)

A. OVER CURRENT CHARACTERISTICS

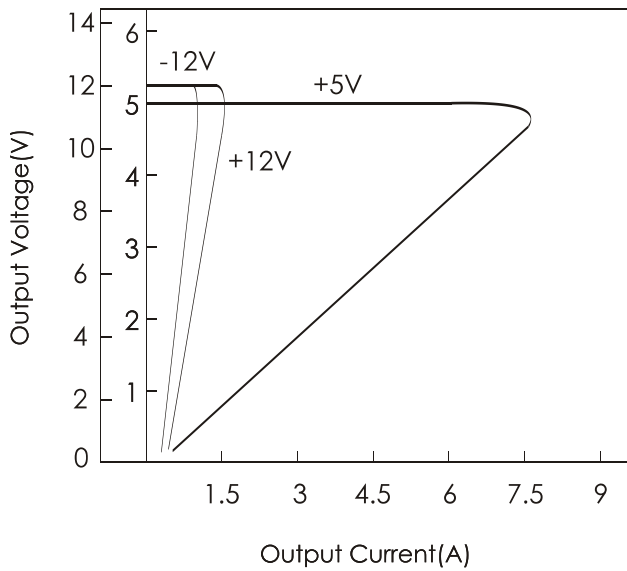

B. DERATING CHARACTERISTICS

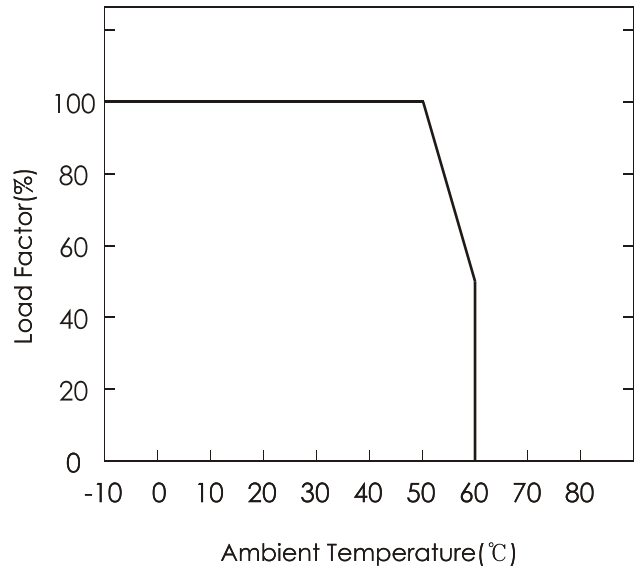

C. EFFICIENCY CHARACTERISTICS

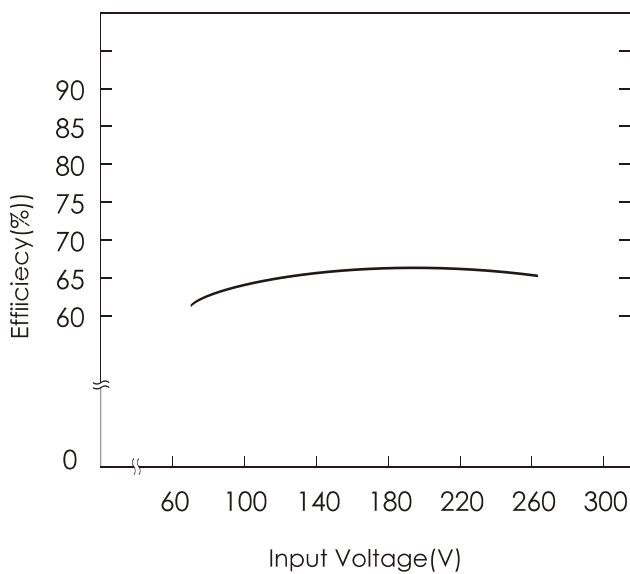

D. RISING/FALLING TIME CHARACTERISTICS

